

RATIO	a	b	c	t	B
32:1	.787 [20]	.236 [6]	1.69 [43]	.885 [22.5]	28.54 [725]
8:1/16:1	1.181 [30]	.314 [8]	2.36 [63]	1.299 [33]	28.58 [726]

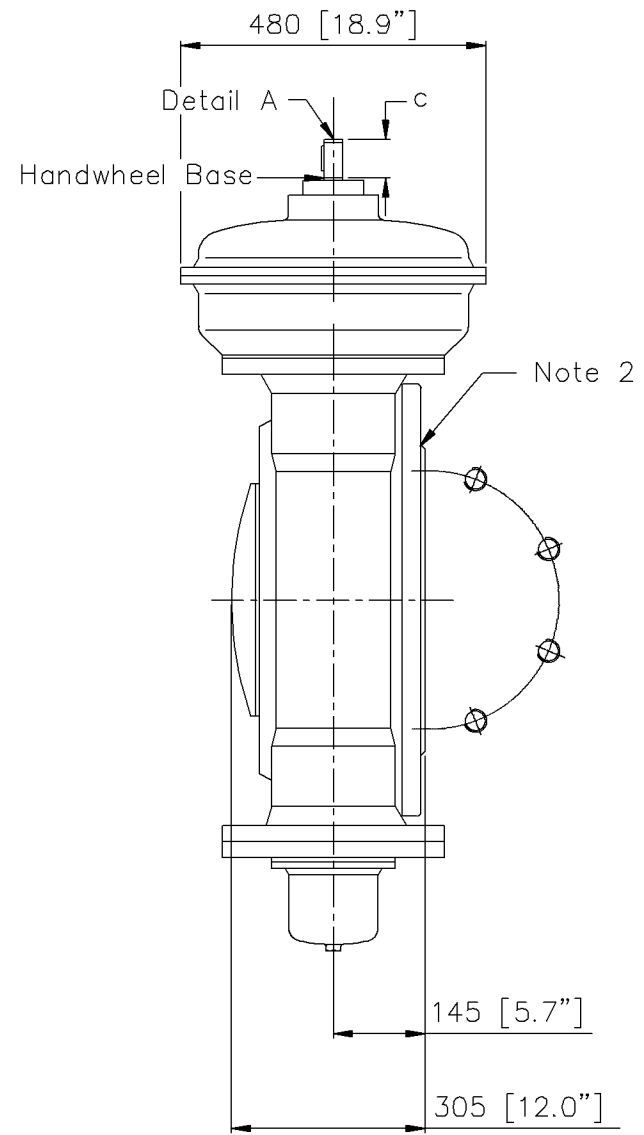
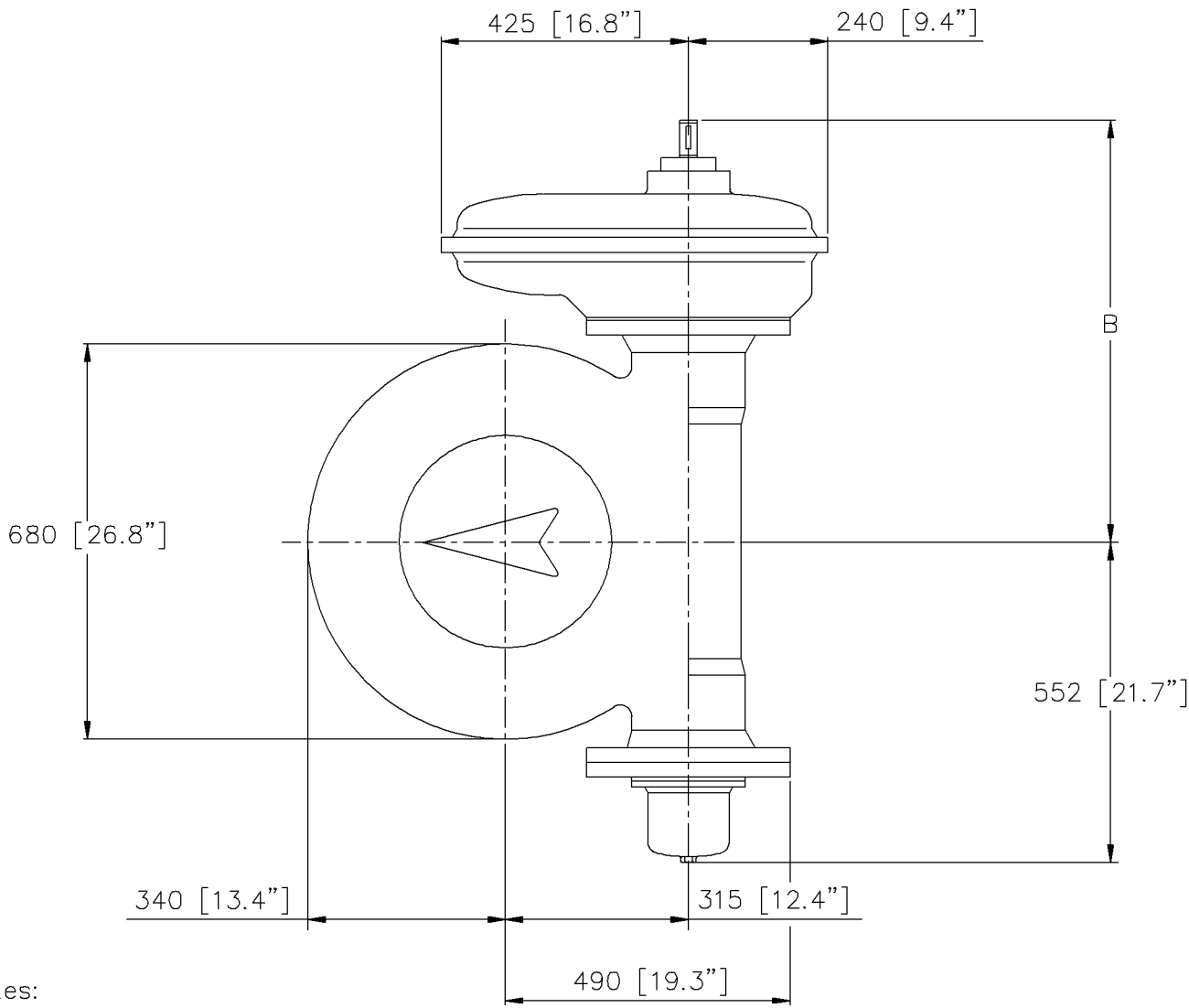
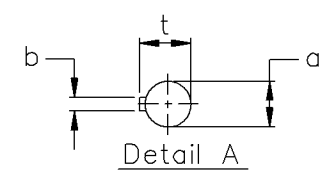

Notes:

1. Metric tolerance per ISO 2768-m. Dimensions in brackets [] are in inches and rounded to one decimal place.
2. See appropriate mounting flange drawing.
3. See drawing S0700423 when using a handwheel.
4. Consult factory for more detailed dimensionals.
5. Gearbox dimensions will not exceed drawing dimensions.

auma ACTUATORS INC.	GS 315 / GZ 30.1 (STYLE RR - RL)		TITLE BLOCK	JP	UK	1
	DESCRIPTION	BY / DATE	APP / DATE	REV		
REF. No.	DWG. No.	SD110057				